



ARTS COMMISSION

Monday, January 10, 2022

5:00 p.m.

<https://lagunabeachcity.zoom.us/j/96691029889>

(669) 900-9128

ID # 966 9102 9889

Telephonic and Virtual Public Participation – You may submit comments on any agenda item or on any item not on the agenda in writing via mail to the Arts Commission at 505 Forest Avenue, Laguna Beach, CA 92651 or via email to AC@lagunabeachcity.net. Please email your comments at least 48 hours before a meeting.

To participate in the meeting click this link <https://lagunabeachcity.zoom.us/j/96691029889> you may comment over the phone or computer during the designated public comment periods. Or call (669) 900-9128 and enter the meeting ID number 966 9102 9889. When an item you wish to comment on is discussed, click on **Raise Hand** or press *9 on your phone. When it is your turn, staff will unmute your microphone and announce your name, allowing you to comment.

- A G E N D A -

- 1) Call to Order
 - 2) Approval of Minutes
 - 3) Chair's Announcements (Schwerner)
 - 4) Commissioner and Staff Communications
 - 5) Public Communications - *In order to assist the Arts Commission in the timely completion of its business, speakers are asked to limit their presentation to three minutes or less.*
 - 6) Cultural Arts Funding Presentations:
 - Laguna Beach Live!
 - Laguna Beach Concert Band
 - 7) Items for Discussion and Action:
 - A. Temporary Sculpture Installation by Vladimir Kush** – Discuss and approve a temporary installation by Kush Fine Art of the sculpture “Segway Seahorse” by Vladimir Kush for installation on the Promenade on Forest. (Ballard/Poeschl)
 - B. Temporary Sculpture Installation by Gerard Stripling**- Discuss and approve a temporary installation by the Laguna Art Museum of the sculpture “Anastasis” by Gerard Stripling at City Hall. (Ballard/Poeschl)
 - C. Sunset Serenades** – Discuss and approve the performers for the four concerts on May 6, 13, 20 and 27, 2022. (Kollenda/McGregor)
 - D. Utility Box Public Art Installation**– Discuss and provide feedback as to the level of interest in facilitating the program. (Ballard/Poeschl)
 - 8) Adjournment
- cc: City Manager, City Clerk, Council Liaison Mayor Pro-Tem Kempf, Assistant City Manager

Post through January 11, 2022



LAGUNA BEACH ARTS COMMISSION

Regular Meeting

Monday, December 13, 2021

Virtual Meeting

5:00 p.m.

Recap of Minutes

PRESENT: Commissioners: Donna Ballard, Suzi Chauvel, Michael Ervin, Pat Kollenda, Adam Schwerner, Karen Wood.
ABSENT: Laura Ford, Suzanne Mellor
COUNCIL: Mayor Pro-Tem Kempf **STAFF:** Sian Poeschl and Michael McGregor.

- 1) Adam Schwerner called the meeting to order at 5:00 p.m.
- 2) Minutes of the September 13, 2021, meeting were approved as presented. M/S Kollenda/Wood.
- 3) **Chair's Announcements:** Adam Schwerner noted that CBS Mornings had aired coverage of chalk artist, David Zinn's 2021 visit to Laguna Beach and was available to view on YouTube.
- 4) **Commissioner and Staff Communications:** Mayor Pro-Tem Kempf noted that the winners of the Children's Holiday Palette exhibition would be recognized at the City Council meeting on December 14, 2021. Staff Poeschl thanked everyone who participated in the workshops and interviews with Cultural Planning Group for the public art ordinance and policy development. Staff Poeschl noted that the City's Public Works department accepted an award from the American Public Works Association for the Main Beach Restrooms which included the mural "Outburst" by Lynn Basa. Staff Poeschl noted that the City was accepting applications for 2022-23 Cultural Arts Funding grants and there would be a webinar to review the application process. Staff McGregor noted that there would be no performances on the Promenade on Forest from December 20, 2021, to March 1, 2022.
- 5) **Public Communications:** None.
- 6) **Cultural Arts Funding Presentations:** Cathy Robin and Patti Jo Kiraly presented on behalf of LagunaTunes Community Chorus regarding how they spent their Cultural Arts Funding grant in 2021.
- 7) Items for Discussion and Action:
 - A) **Art-in-Public Places – 1391 South Coast Highway (Coast Liquor)** – Staff Poeschl introduced the proposal and artist Casey Parlette. Mr. Parlette presented the proposed design for a wall mounted sculpture and provided material samples of bronze, redwood and titanium. Chair Schwerner asked about the installation height of the work which the artist responded would be eight feet above the existing bougainvillea hedge. Commissioner Suzi Chauvel inquired about the ombre plastering, the artist noted the installation method and subtle coloring. A motion was made to recommend approval of the proposal to City Council to satisfy the Art in Public Places requirement of the City's Municipal Code. M/S Kollenda/Wood. Yeas: Ballard, Chauvel, Ervin, Kollenda, Schwerner, Wood. Noes: None.
 - B) **Children's Holiday Palette Exhibition** – Staff McGregor noted there were 98 entries and presented the Palette Subcommittee recommendations for the 2021 exhibition. A motion was made to ratify the Subcommittee's selection of twelve designs for display. M/S Chauvel/Kollenda. Yeas: Ballard, Chauvel, Ervin, Kollenda, Schwerner, Wood. Noes: None.
 - C) **Temporary Art Installation** – Staff Poeschl noted that the Commission had previously approved an augmented reality installation with a budget not to exceed \$20,000. Staff noted that the Public Art Subcommittee

recommended pursuing the project with a different artist. Staff noted that artist Nancy Baker Cahill had expressed interest in the project but would need a stipend to develop a proposal. Pat Kollenda expressed concerns over the engagement barrier of requiring a smart device to experience. A motion was made to approve working with Nancy Baker Cahill and a budget of \$3,000 for the artist to develop a proposal. M/S Ballard/Ervin. Yeas: Ballard, Chauvel, Ervin, Schwerner, Wood. Noes: None. Abstained: Kollenda

D) **Year-End Review** – Staff McGregor presented the Year-in-Review document. A motion was made to approve the document and direct staff to share it on the City’s website and Cultural Arts newsletter. M/S Wood/Kollenda. Yeas: Ballard, Chauvel, Ervin, Kollenda, Mellor, Schwerner, Wood. Noes: None.

8) Adjourned at 6:05 p.m.

cc: City Manager
City Clerk
Mayor Pro-Tem Kempf
Assistant City Manager



March 24, 2021

Cindy Prewitt
Laguna Beach Live!

Dear Cindy:

On behalf of the City of Laguna Beach, I am pleased to present a grant of **\$28,000** to Laguna Beach Live! to support your organization's work in 2021-2022. This funding should be used to fund musicians and production costs in presenting Jazz Wednesday, a Winter and Spring Concert, Bluegrass and BBQ and the Laguna Beach Music Festival in 2022. This grant program is made possible from revenues of the Laguna Beach Tourism Marketing District. The use of these grant funds should be acknowledged in written materials by a statement that **"funds for this program are provided by the lodging establishments and the City of Laguna Beach."**

The City of Laguna Beach Arts Commission will be reviewing a final report on your use of these funds in early 2022. The Commission will be inviting your organization to its meeting to give an overview of your programming and use of the funds. The report form will be mailed to you early next year.

Once again, congratulations! I hope this funding will assist your organization in realizing the full potential of your projects and you continue to thrive for the benefit of Laguna Beach.

Sincerely,

Bob Whalen
Mayor



March 24, 2021

Brad Balen
Laguna Community Concert Band

Dear Brad:

On behalf of the City of Laguna Beach, I am pleased to present a grant of **\$5,000** to the Laguna Community Concert Band to support your organization's work in 2021-2022. This funding should be used to perform at the Laguna Beach art festivals, Main Beach, Susi Q, Promenade on Forest, and Laguna Playhouse. This grant program is made possible from revenues of the Laguna Beach Tourism Marketing District. The use of these grant funds should be acknowledged in written materials by a statement that **"funds for this program are provided by the lodging establishments and the City of Laguna Beach."**

The City of Laguna Beach Arts Commission will be reviewing a final report on your use of these funds in early 2022. The Commission will be inviting your organization to its meeting to give an overview of your programming and use of the funds. The report form will be mailed to you early next year.

Once again, congratulations! I hope this funding will assist your organization in realizing the full potential of your projects and you continue to thrive for the benefit of Laguna Beach.

Sincerely,

Bob Whalen
Mayor

MEMORANDUM

DATE: December 7,2021
TO: Arts Commission
FROM: Siân Poeschl, Arts Manager
SUBJECT: **Temporary Public Art Installation (Kush Fine Art) (Item A)**

An application has been submitted by Kush Fine Art Gallery, which is located on Forest Avenue, to install a sculpture on temporary exhibit on the Promenade on Forest. The application identifies the sculpture being donated to the City of Laguna Beach, however the applicant has clarified the proposal would be on loan at no charge for a period of up to 24 months.

The sculpture is titled, "Segway Seahorse" by Vladimir Kush and is created of bronze mounted onto a concrete base clad in granite. The application requests the piece be installed on the existing asphalt located between two existing sculptures titled "Waves" by Larry Gill and "Promenade Blocks" by Marlo Bartels. The applicant has proposed two options of scale the first standing 8.5' in height (including the base) and the second at 7' (including the base.) The Gallery has indicated the concrete block base will be heavy enough to not need any form of attachment to the asphalt. However, the 7' sculpture would require some form of attachment into the asphalt. All costs associated with the installation would be facilitated and funded by Kush Fine Art Gallery. The location is in close proximity to the gallery whose staff would clean the sculpture on a weekly basis.

The City currently has two approved locations for the exhibition of temporary public art works, located outside City Hall and near the amphitheater in Hesler Park. Both locations have been reviewed and approved by the Planning Commission who issued a Temporary Use Permit for the locations to exhibit public art works. Currently, the location on the Promenade on Forest was not a consideration and will need Planning Commission and City Council approval.

The Commission should also consider that a number of other galleries conduct business on the Promenade on Forest, and although they have not expressed an interest or the generosity of Kush Fine Art Gallery, consideration should be given to additional requests should they be made.

The sub-committee did review the application and have not made a recommendation and that the application and considerations be reviewed by the entire Commission. Attached is the application with images of the location, information about the artist and the inspiration for the work.

Attached: Vladimir Kush Application

City of Laguna Beach

ARTS COMMISSION APPLICATION

Name: Kush Fine Art Gallery

Address: 210A Forest Ave. Laguna Beach, 92651

Phone / Fax: (949) 376-8017

Date: 11/19/2021 Contact person: Jorge Barrera, Marketing Director (702-982-9902).

Art in Public Places – required by the Municipal Code

Property Information:

Location: Promenade on Laguna Beach City on Forest Ave. and Pacific Coast Highway.

Property owner: City of Laguna Beach

Description of Project: (Additional information may be attached. Please include materials, maintenance schedule, site drawing, colored drawing of installation and photograph of location.)

“Segway Seahorse” Bronze Sculpture (Additional and supporting information attached).

Dimension of site: Approximately 20 ft x 18 ft.

Dimension of proposed art work: A) 8.5 ft tall including base or B) 7ft tall including base (Specific dimensions on document attached).

Estimated cost: \$30,000 (Donated by Artist to the City of Laguna Beach).

Maintained by: Kush Fine Art

This form must be submitted to the Cultural Arts Department for consideration at an Arts Commission meeting.

Signature: Vladimir Kush 

For Cultural Arts Department Use

Date received: _____ Arts Commission agenda date: _____

Application # _____

Date _____



VLADIMIR KUSH

AND KUSH FINE ART

P R E S E N T

“SEGWAY SEAHORSE”

In Laguna Beach, CA



Segway Seahorse by Vladimir Kush

No doubt you are seeing the new species of fauna, created by the artist's imagination. The new artifact belongs to both elements: Ocean and Earth. The head and the shape of the neck of the seahorse resemble the chess horse. It is covered with the spikes and shields just as an armory is covering the head of the knight horse. As a seahorse, the creature could be moving up and down under the water, but the wheel allows him to roll in a horizontal direction. As magic, he rolls out of the sea and turns into the circus performer. The silence of the ocean is changed to the earthly sounds of applauding! Before he swam slowly around the corals and hooked up his tail to the seaweed, now he is involved in the hectic downtown life.

The headlight allows him to find its way through the streets at night. The fin behind resembles the wing of the horse with wings- the Pegasus, beloved by the Muse.

His name meaning as " turbulent sea" comes from his birthplace at the origin of the sea



Since Laguna Beach symbolizes the connection of the Ocean and the Land, the Artist believes that the Segway Seahorse reflects the connection between the two elements: the Earth and the Ocean. Being installed at the heart of Laguna Beach town, the connection to arts and music is apparent through the symbolism of the Pegasus, the winged horse.

Proposed Project for “Segway Seahorse” in Laguna Beach Promenade on Forest Ave.

Specifications: (Option A)

Sculpture Height: 8.5 ft tall (Including Base).

Base: Concrete cube (35.5”x 35.5”x37”) matching the same size as the cubes already on site on Forest and Pacific Highway and the tile finish matching the waves on each side on the planters.



**Proposed Project for “Segway Seahorse” in Laguna Beach
Promenade on Forest Ave.**

Specifications: (Option B)

Sculpture Height: 7ft tall (Including Base).

Base: Concrete cube (35.5”x35.5”x18.5”) at half the size as the cubes already on site on Forest and Pacific Highway and the tile finish matching the waves on each side on the planters.



THE ARTIST'S CREDO

To reflect the world in the mirror of the metaphor - this is the goal of the artist. Metaphor does not only belong to linguistic communication but can also be found in our daily life. Metaphor is the means of communication that we live by. First of all, the metaphor is aimed at the viewer's feelings and subconscious. It gives full rein to imagination, as it is the imagination that creates the connections between two seemingly different things. "Imagination is more important than knowledge. Knowledge has its limitations, while imagination has no limits." ~Albert Einstein Metaphor leaves the mind open to grasp onto the hidden likeness of things and events. And the more distant these things are, the greater the effect. The unexpectedness of the connection and sudden insight, which takes your breath away, is the true measure of the painting's value, according to the artist. Different from art that leaves us in speechless admiration (realism) or suggests we solve a puzzle made of symbols (abstract art), metaphorical art challenges our subconscious with the symbolism of artifacts. Any metaphor has its own story to tell. Metaphor "sees" through centuries, unveiling the images of the world and connecting notions created by civilization. At the same time, metaphor can easily reflect the complexities of our modern life, with its ambiguity and contradictions.

The painter's mission is to find a metaphorical "parallel" for every side of real life. The element of unexpectedness will shake up the viewer and awaken his artistic nature. The artist believes that the viewer's insight comes at once. It is not about discovering something new. His concept is similar to that of Plato who believed there is an ideal world, a "cave" that human souls once dwelled in. The "cave" retained their core ideas of things after they left. Therefore, the insight that comes when viewing art is a recollection of that. The artist's role is to stimulate this subconscious process of remembering through his art.

ABOUT THE ARTIST

Vladimir Kush is one of the most original artists of our time. Through hard work and talent, he became the founder of a new branch of art - metaphorical realism -, which is showcased throughout the world and in several of his own galleries. In 25 years (17 years since Santa Monica...), he transformed himself from a struggling artist who earned his living by drawing portraits on the beaches of Santa Monica, to a major artist recognized on both sides of the Atlantic. Vladimir's American odyssey began in 1990 when he chose not to return to Russia and flew to Los Angeles. His first few years in the United States required a lot of perseverance and hard work. Finding oneself, the ebb and flow of artistic ideas, and the search for a style of your own is a long and winding path that remains hidden from the public eye. It runs in the dark, like the inner workings of the mind - the depths of subconscious - and must mature like a chrysalis on its way to becoming a butterfly. This is a critical stage of development during a formative time in the life of an artist. At the end of nearly a decade of unceasing effort in a foreign land, 1998 brought the starting point of Vladimir's success as a professional artist and the founder of a new art style. By that time his most notable works - Wind, Fauna in La Mancha, Bound for Distant Shores, Nero, Sunrise by the Ocean, Music of the Woods, Candle, Atlas of Wander, and others - formed the defining examples of his method and laid the foundation for metaphorical realism. In 2001, with the opening of the first of his galleries in Lahaina on the Hawaiian Island of Maui, the American cultural environment accepted the artist and his vision. Metaphorical realism and the Kush Fine Art brand were established. It is worth noting that he settled on an exotic island in the Pacific, of which he dreamed as a boy but could not visit from behind the Iron Curtain that was the Soviet Union. Now KFA owns a number of large high-end galleries across the United States and has permanent exhibitions worldwide.

One of the strongest motives behind Vladimir's continuing hard work is knowing that he is the only American artist of Russian origin in the United States who is not only productive, but also a successful and independent manager of his own enterprise in a country with a highly competitive environment. His enormous everyday efforts were rewarded in producing more than 150 paintings (not counting drawings, watercolors, designs, etc., since the publication of *Metaphorical Journey*, his last book) and 50 sculptures and jewelry pieces. Collectors and admirers of his art come from all over the world, as well as imitators and forgers. Original paintings are purchased quickly, sometimes as early as when the subject of a future piece is announced. At this point, the priming is still fresh on the canvas but the concept has taken life in the artist's imagination. The success of Vladimir's artwork has much to do with the unexpectedness of the subject and its freedom from any constraints of location or bias. He is therefore rightly referred to as the 'artist of the world'. In this, Vladimir follows one of the injunctions in Salvador Dali's *50 Secrets of Magic Craftsmanship* that suggests you stick to your own vision, your own style...this will come in handy if you become an artist.

International recognition came to Vladimir in 2012, at the *Artistes du Monde – Cannes Exposition Internationale*, when he received the prestigious First Prize in Painting, which was presented to him by Marina Picasso. However, it is the recognition of collectors and admirers that Vladimir appreciates most. His paintings are inspiring young artists and appealing to professional writers and musicians, who incorporate his images on the covers of their releases and books. The main focus of Vladimir's art has always been in painting and drawing, and yet the ideas that have grown on the flat surface of the canvas have gradually acquired one more dimension and transitioned into 3D space. Turned out in bronze, silver, and gold, strengthened by the shine of patina or the sparkle of precious stones, they received their shape and reached their fullness in metaphorical sculpture and jewelry.

There are but a few branches of contemporary art that can undergo this kind of transfer. Metaphorical realism is so rich in ideas that the images it creates find their place in virtual reality too: in 2014 an electronic coloring book entitled "Aries the Sheep" was created for Apple™ users. This app was such a success with children all over the globe that it won the Ehon Award in Tokyo after being chosen from more than 200 electronic childrens' books from all over the world, games, and educational programs. Another interactive project – *The Story 1&0* – followed in 2016. For Vladimir Kush, working with children goes beyond creating games and stories. He believes that children have an intact "inner region of fantasy," which can be lost as we get closer to adulthood. At maturity, this imaginative ability is replaced by the practical drive for survival and the everyday dynamics of life. Therefore, works by the artist can be used successfully to help develop cognitive abilities.

Among more than 200 entries for "Where Does the Sun Go?" a creative work competition organized by Kush Fine Art as part of the School Community Partnership Program of Nevada, many participants presented a deep interpretation of the title subject and were highly regarded by the founder of metaphorical realism. This program highlighted how perceptive a child's mind is of everything that surrounds us. Henry Miller recognized that although people think they are surrounded by the facts of life, they don't realize that they are walking through the forest of symbols. Our thinking is, in essence, metaphorical. We use metaphors every day in spoken language – often without realizing that the impact from the visual metaphor may be even more powerful than the spoken metaphor. Vladimir Kush's style of metaphorical realism is an evolution of this thought process. However, no contemporary style can rescue a bad painting, so it is worth remembering one more dictum from Dali, the great master: "Begin by learning to draw and paint like the old masters"

Installation:

The concrete block on option A will be heavy enough not to have to be attached to the asphalt. This will probably weigh in over 1000lbs so it won't be something that moves and that is why we would rather do the large cube to match the existing cubes and not to touch the asphalt. The concrete cube would have a hole in the center and the sculpture would be bolted to the center of the cube. The cube would have to be installed with a crane. Also, as already mentioned, Kush Fine Art would cover the expenses and cost as a thank you to the City of Laguna Beach.

If we install the smaller cube on Option B, then this would require drilling into the asphalt and epoxy and attach to the base. Since it is a temporary sculpture for now, this wouldn't be the best option, unless the city wants to use this option B as a permanent sculpture.

Maintenance:

Regarding the maintenance schedule, we would have our staff clean the sculpture on a weekly basis and make sure it is properly waxed once or twice a month as needed.



Kush Fine Art Gallery has been part of Laguna Beach for over 16 years, greeting thousands of locals and visitors throughout the years, and it has become a landmark for arts and culture in the heart of the city.

Kush Fine Art Laguna Beach is located in the heart of the Artist Colony on Forest Avenue. Laguna Beach is the home of the "Festival of Arts and Pageant of the Masters" bringing in art enthusiasts and collectors from all corners of the earth. For the beachgoers and surfers, the seven miles of picturesque Pacific coastline offers plenty of pristine sandy beaches and up to 15-foot waves, some of the best in Southern California! Kush Fine Art Laguna Beach was opened by Vladimir Kush in 2006.

Embarking visitors into a Metaphorical Voyage into a world of the unknown, to a place where you only have to start noticing around you, and the miracle of connection is everywhere! Kush Fine Art is one of a kind art gallery in the industry of fine art, featuring the unique a collection of original paintings, prints, drawings, jewelry, art, books, bronze and silver sculptures, and wearable art. Visiting our gallery will be the highlight and ultimate destination for anyone who maintains imagination, intellect, and exquisite taste for all genres of art.

Kush Fine Art Gallery
210A Forest Ave.
Laguna Beach, CA 92651
www.kushfineart.com

MEMORANDUM

DATE: January 4, 2022
TO: Arts Commission
FROM: Siân Poeschl, Arts Manager
SUBJECT: **Temporary Public Art Installation (Laguna Art Museum)** (Item B)

An application has been submitted by the Laguna Art Museum, to install a sculpture on temporary exhibit on the front lawn of City Hall. This is the first request by a non-profit organization to utilize the space for a temporary public art installation. The application notes the exhibition period of one month from February 1 to 28, 2022 of the sculpture “Anastais” by Laguna Beach artist Gerard Stripling. The installation will be part of programming celebrating February as Ethnic Diversity and Black History Month.

The proposed sculpture is 12’4’ in height by 5’7” in width and is created of corten steel and glass. The sculpture will be mounted onto 5’ x 5’ x 1” steel plate. The base will be surrounded by a steel banding into which will be installed compacted rock concealing the mounting of the sculpture. Surrounding the sculpture will be five seating elements where people are encouraged to gather. The seating stools will each measure 18” in height by 24” in width with a concrete seat and steel cladding structure. Drawings, dimensions, and placement details are included in the attached proposal. The sculpture will be illuminated with a solar powered lighting installed in the compacted stone base for visibility and public safety at night.

All costs and facilitation of the project will be funded by the Laguna Art Museum and installation and de-installation will be undertaken by the artist. The Ethnic Diversity Celebration and Laguna Art Museum will host a dedication ceremony on Wednesday, February 9, 2022.

It is recommended the Arts Commission consider the request of the Laguna Art Museum and take the necessary action.

Attached: Laguna Art Museum Application



LAGUNA ART MUSEUM

January 3, 2022

Siân Poeschl, Cultural Arts Manager
City of Laguna Beach
505 Forest Avenue
Laguna Beach, CA 92651

Dear Siân:

A group of residents from Laguna Beach have joined together with the idea to create an Ethnic Diversity Celebration in Laguna Beach. Our community, which has long been at the forefront of inclusiveness, is made up of individuals that bring diversity and vibrancy to our community. The desire is to celebrate this in a public way.

This is the inaugural year of the Ethnic Diversity Celebration in Laguna Beach. Community members and organizations have quickly embraced the idea and are contributing in many different ways throughout the city. In addition to hosting a program at the museum that celebrates African American culture in partnership with the Segerstrom Center, I have volunteered to help curate and organize an appropriate work of art that can, with the city's approval, be installed publicly and unveiled as the main kick-off to a series of a month of events.

I have selected Laguna Beach artist Gerard Stripling for this inaugural project. He is the ideal candidate as he has contributed to the arts in our city for over 20 years. His work asks us to be positive and thoughtful, to have empathy for others and to remember that we all have potential to make a difference. As a plus, Stripling has worked with the City of Laguna Beach before and understands the requirements for a successful outcome. The artist's resume accompanies this letter, below is additional information for your consideration.

Thank you for this opportunity,

Julie Perlin Lee
Laguna Art Museum, Executive Director

Artist: Gerard Basil Stripling

Artwork Title and Date: Anastasis, 2022

Material: Corten steel, glass and gravel

Overall dimensions: 12'0" tall by 15'0" wide

Exhibition Duration: February 1 – March 1, 2022

Wednesday, February 9, 2022 unveiling of sculpture in conjunction with Ethnic Diversity Celebration

Installation Dates: January 26-28, 2022

Installation team and method: At a centralized area on the lawn outside City Hall, a steel spread plate measuring 5' x 5' and 1" thickness. The footing will be on the surface of the ground and surrounded with a steel band which will be filled with compacted rock, concealing the sculpture's footing. The sculpture will be affixed to the footing base with hardware.

To entice onlookers to come together around the sculpture, five round stools created of a concrete seat and corten-steel structure each measuring 24" wide by 18" tall with will be placed around the circle. The seating will be positioned 5'10" apart and 3'4" from the sculpture to allow for ADA accessibility. The sculpture will be illuminated with solar powered lighting installed in the gravel base for visibility and public safety at night.

Deinstallation dates and method: Sculpture will be removed the week of February 28, 2022 by the artist. Laguna Construction and Builders will remove concrete footing and replace disturbed sod.

Plaque:

Anastasis, 2022

By Laguna Beach artist Gerard Basil Stripling

A sculpture about new beginnings installed on the occasion of the 2022 Laguna Beach Ethnic Diversity Celebration.

Drawings and Images:

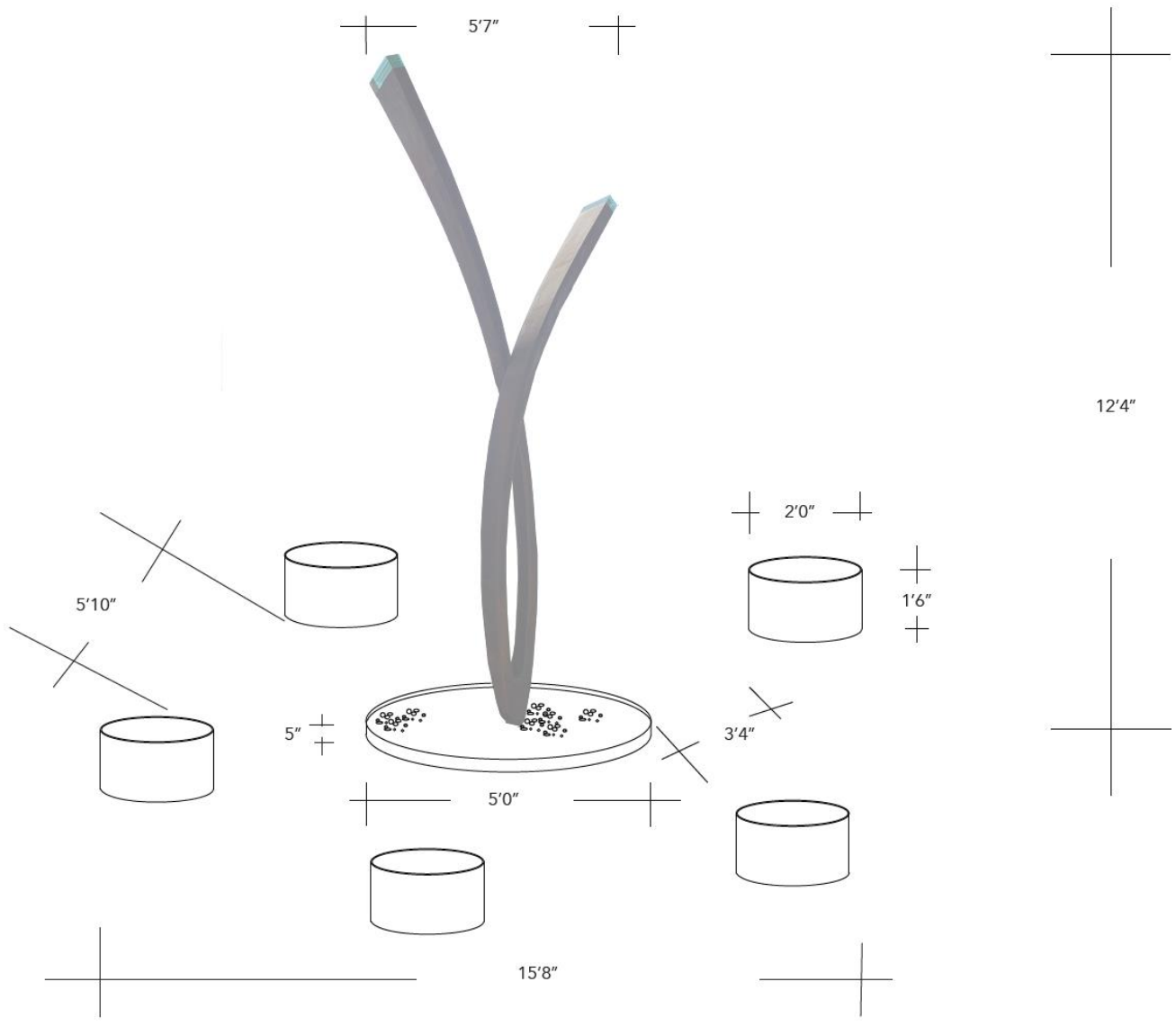

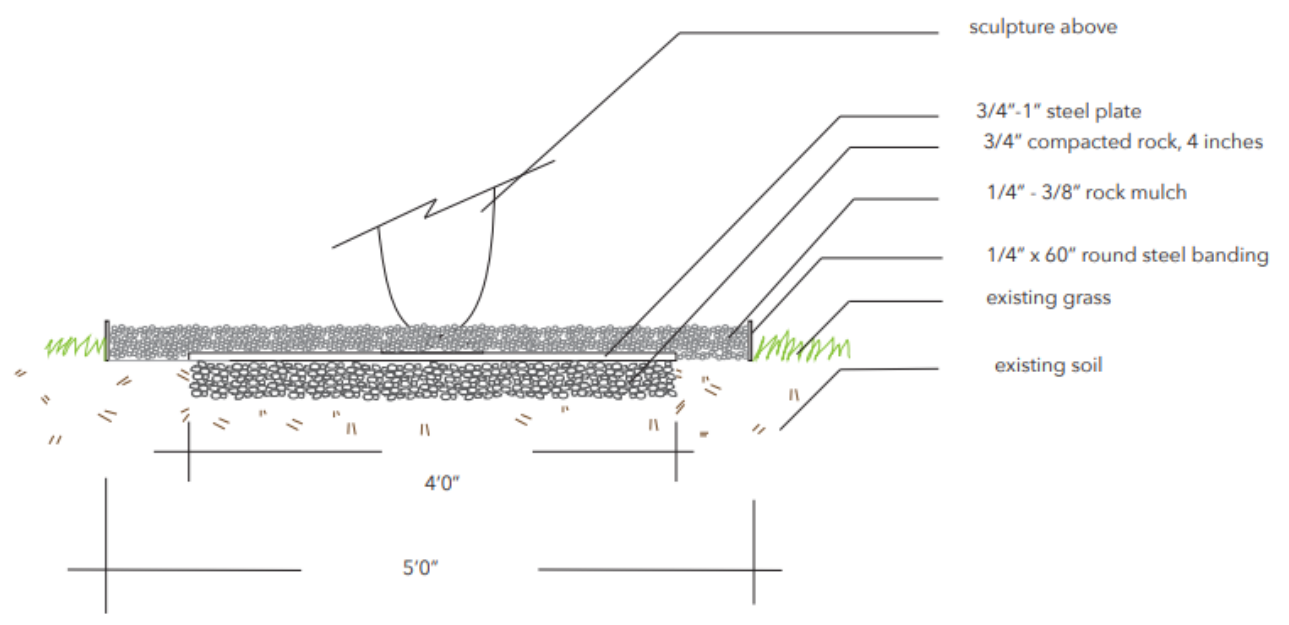
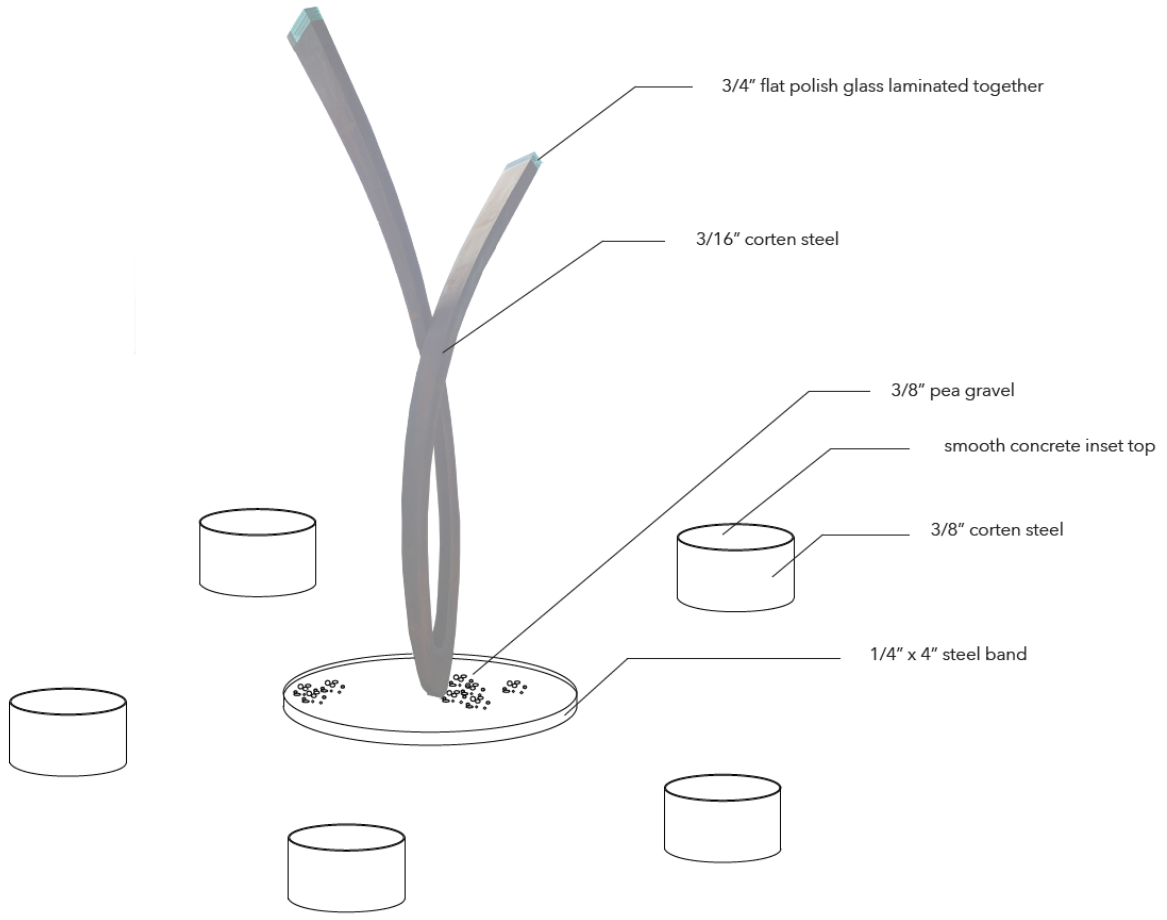

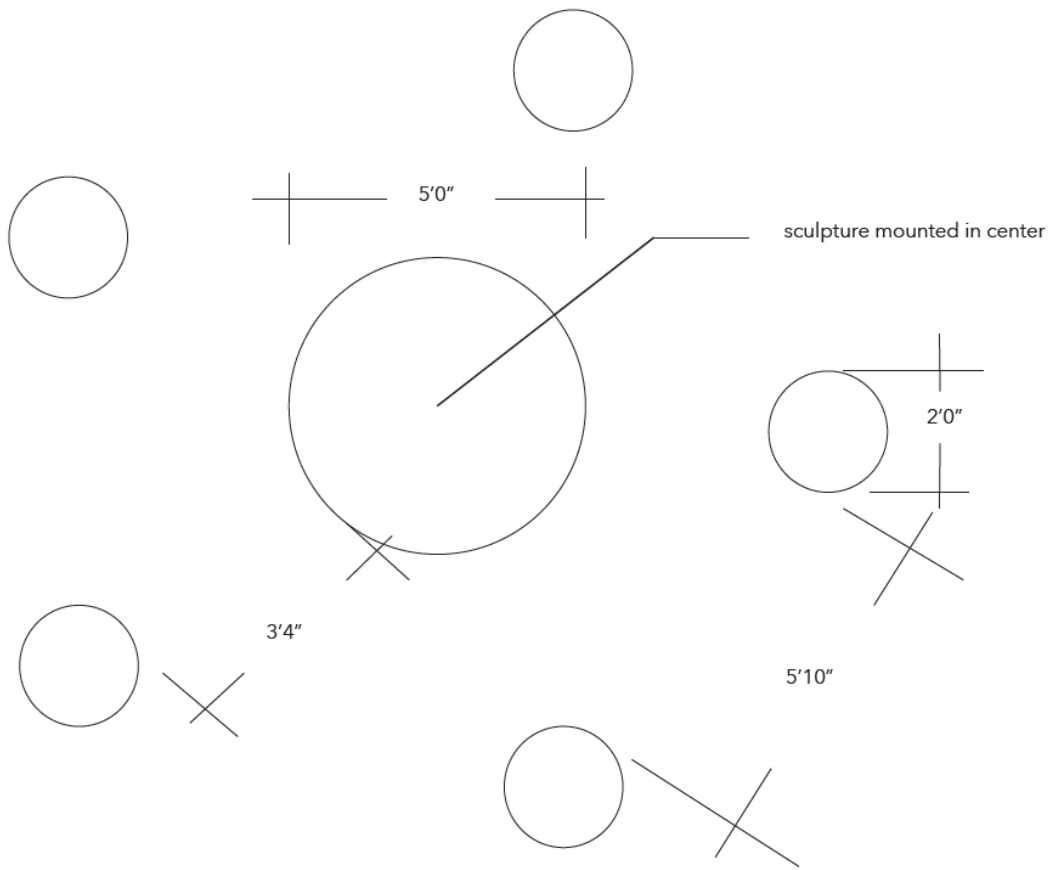

birds eye view

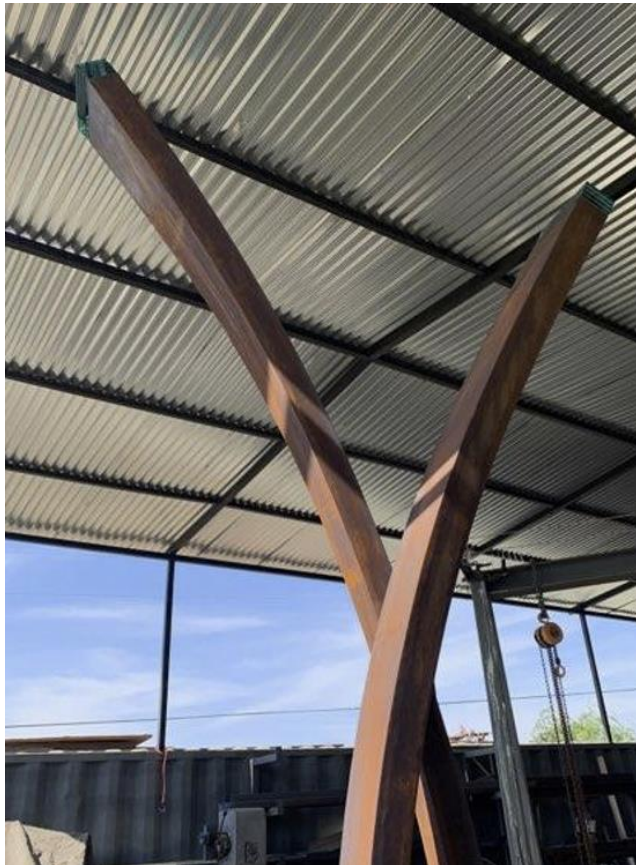

**City of Laguna Beach
Cultural Arts Department
Staff Report**

To: Arts Commission
From: Mike McGregor, Arts Program Coordinator
Agenda Item: C
Title: Sunset Serenades – Spring 2022 Performers
Location: Laguna Beach, CA

Overview

Sunset Serenades is a free public concert series held each Friday evening in May and September at the Heisler Park Amphitheater. Spring concerts take place from 6:30 p.m. to sunset. On October 11, 2021, the Arts Commission approved spring 2022 concert dates for Sunset Serenades. The concert series will be subject to county and state health guidelines regarding COVID-19.

Summary of the Matter

The Sunset Serenades performances are curated with the help of local musician Jason Feddy. The Performances Subcommittee consisting of Pat Kollenda, Suzi Chauvel and Karen Wood is recommending the following schedule for May 2022:

5/6	Eric James Larson	Singer-songwriter	https://www.youtube.com/watch?v=b-NtFO4Eto4
5/13	Carolyn Richardson	Vacation soul inspired by classical	https://www.youtube.com/watch?v=k9dUeFSX3nw
5/20	David Witham / Billy Mohler	Jazz	https://www.youtube.com/watch?v=kawB2be_V-M https://en.wikipedia.org/wiki/Billy_Mohler
5/27	Acoustic Asylum	Eclectic strings and accordion music	https://www.youtube.com/watch?v=RsdFR5CigAY

Recommendation

It is recommended that the Arts Commission approve the Sunset Serenades performers as presented.

MEMORANDUM

DATE: December 29, 2021
TO: Arts Commission
FROM: Siân Poeschl, Arts Manager
SUBJECT: **Utility Box Public Art Program** (Item D)

Numerous cities throughout Orange County have undertaken utility box public art programs. These programs utilize city owned utility boxes which are either wrapped in a vinyl print or hand painted by the artist. Most installations are bright and graphic and have a large sidewalk space around them.

Examples of cities who have undertaken the program are:

[City of Dana Point](#)

[City of Costa Mesa](#)

[City of Santa Ana](#)

[City of Fountain Valley](#)

[City of Fullerton](#)

[City of Long Beach](#)

City Council Member Toni Iseman has inquired as to whether the Arts Commission has considered such a program in Laguna Beach. On May 18, 2016, the Arts Commission considered the program, estimated costs of vinyl wrapping and the Mural Sub-Committee met and made no further recommendation. The memorandum and Arts Commission minutes are attached to this report.

The Arts Commission should consider that there is a need to identify the owner of each utility box and fully understand the parameters each utility company would have on the use of the box, including any liability and ownership requirements. In an email, Council Member Iseman noted she did not see the need for the Arts Commissions involvement, but by wrapping the boxes would beautify the city for the walking community.

The Public Art Sub-Committee consisting of Donna Ballard, Suzi Chauvel and Adam Schwerner met and are not recommending this program as part of the City's public art initiatives. The committee felt the program is not original to Laguna Beach such as the Palette Program, that many existing utility boxes are at busy intersections or narrow sidewalks creating more blight than beautification and would be visual competition to nearby businesses.

The Arts Commission should consider the project and discuss the level of interest of undertaking this program, if there is no interest, the program of beautification would perhaps be facilitated by Public Works.

MEMORANDUM

DATE: May 18, 2016
TO: Arts Commission
FROM: Siân Poeschl, Cultural Arts Manager
SUBJECT: **Utility Box Beautification Program**

Councilmember Zur Schmiede shared information regarding a utility box beautification program being considered by the City of Long Beach. The City of Long Beach initially had artist painted utility boxes, but following vandalism is considering vinyl cabinet wraps.

The City of Long Beach is considering the services of the Clean Slate Group for the installation of graffiti-resist vinyl wraps. The company facilitates the cabinet wraps from concept exploration to installation, support services and warranty.

1. Anti-graffiti material
 - Clean Slate worked directly with 3M to pioneer their films for anti-graffiti.
 - Clean Slate material is high quality laminate with UV protectant and is non-flammable / self-extinguishing.
 - Clean Slate has the ability to wrap complex curves, hinges welds, vents, handles.
 - Cabinet wraps minimize the space to be vandalized.
2. Artwork, Sponsors
 - Clean Slate can engage the art community to display their art or local photographers on behalf of the City if desired.
 - Clean Slate will create a press release for submission calls.
 - Clean Slate's design team will work with the City (on preferred artwork or the Artist to integrate the art into the film.
 - Clean Slate will provide a mock-up for agency approval prior to production (this allows the Artist to submit their "A" game artwork or provide their favorite piece of artwork.
3. Pre-Installation site survey
 - Agency provides list of intersection names.
4. Installation
 - Two Clean Slate "certified installers" provide all installations.
 - Clean Slate has over 1000 boxes presently installed.

The estimate per cabinet is \$1,000 and does not include the artist honorarium.

Arts Commission

May 23, 2016

Utility Box Beautification Program – Staff presented information, shared by Council Member Zur Schmiede, regarding a utility box beautification program in the City of Long Beach. The artist designed, graffiti-resistant vinyl wraps could be installed on signal boxes and cost an estimated \$2,000 per installation. Ruben Flores suggested partnering with the Beautification Council on the project. Sandra Desmond noted the vinyl could be taken off by vandalism. Leah Vasquez suggested boxes in the canyon be considered. Muffin Spencer-Devlin felt they should be originals and painted by the artist. Lorene Auger noted the design could camouflage the boxes and suggested the appearance of bushes. Staff noted that unlike Long Beach, the signal boxes in Laguna Beach were the property of Caltrans and the first step, would be to contact them to garner support. The mural subcommittee will meet to discuss the concept of the project.